



Numération : mathématiques et informatique

RENCONTRE ORGANISÉE PAR :
Boris Adamczewski, Anne Siegel and Wolfgang Steiner

23-27 mars 2009

Thomas A. Schmidt

Rosen fractions and Veech groups, an overly brief introduction

Vol. 1, n° 1 (2009), p. 61-67.

<http://acirm.cedram.org/item?id=ACIRM_2009__1_1_61_0>

Centre international de rencontres mathématiques
U.M.S. 822 C.N.R.S./S.M.F.
Luminy (Marseille) FRANCE

cedram

*Texte mis en ligne dans le cadre du
Centre de diffusion des revues académiques de mathématiques
<http://www.cedram.org/>*

Rosen fractions and Veech groups, an overly brief introduction

Thomas A. SCHMIDT

Abstract

We give a very brief, but gentle, sketch of an introduction both to the Rosen continued fractions and to a geometric setting to which they are related, given in terms of Veech groups. We have kept the informal approach of the talk at the Numerations conference, aimed at an audience assumed to have heard of neither of the topics of the title.

The Rosen continued fractions are a family of continued fraction algorithms, each gives expansions of real numbers in terms of elements of a corresponding algebraic number field. A Veech group is comprised of the Jacobians of locally affine self-maps on a “flat” surface to itself. The Rosen fractions are directly related to a certain family of (projective) matrix groups; these groups are directly related to W. Veech’s original examples of surfaces with “optimal” dynamics.

1. REVIEW OF SIMPLE CONTINUED FRACTIONS

The Rosen continued fractions give one of many generalizations of the classical simple continued fractions (SCF). We briefly review elementary properties of these latter; many standard texts give good expositions of this material.

Each real x has SCF-expansion

$$x = a_0 + \frac{1}{a_1 + \frac{1}{a_2 + \cdots + \frac{1}{a_n + \cdots}}}$$
$$= [a_0; a_1, a_2, \dots, a_n, \dots],$$

whose *convergents* are of the form $p_n/q_n := [a_0; a_1, a_2, \dots, a_n]$.

There is an underlying interval map, for which the SCF encode the dynamics of composing the map. Indeed, this *Gauss map* acts as a one-sided shift on SCF-expansions in the unit interval:

$$T : [0, 1) \rightarrow [0, 1)$$
$$x \mapsto \frac{1}{x} - \left\lfloor \frac{1}{x} \right\rfloor, \quad x \neq 0; \quad (T(0) = 0).$$

1.1. Consecutive convergents give elements in matrix group. By appropriately letting with $\epsilon = \pm 1$, $\begin{pmatrix} \epsilon p_{n-1} & p_n \\ \epsilon q_{n-1} & q_n \end{pmatrix}$ is of determinant one. Furthermore, letting

$$S : x \mapsto x + 1 \quad \text{and} \quad T : x \mapsto -1/x,$$

Text presented during the meeting “Numeration: mathematics and computer science” organized by Boris Adamczewski, Anne Siegel and Wolfgang Steiner. 23-27 mars 2009, C.I.R.M. (Luminy).

2000 *Mathematics Subject Classification*. 37-01, 37-02, 11-01, 11-02, 11J70, 37E35, 37F30.

The author thanks the organizers of *Numeration 2009* for the opportunity to discuss these topics, and MPIM Bonn for its friendly hospitality.

we can at least formally write

$$[a_0; a_1, a_2, \dots] = S^{a_0} T S^{-a_1} T S^{a_2} T \dots .$$

The alternating sign is related to the fact that convergents alternate above and below x . The matrices and these linear fractional maps are of course related.

With the usual möbius action

$$\begin{pmatrix} a & b \\ c & d \end{pmatrix} x := \frac{ax + b}{cx + d},$$

we can recycle notation and let

$$S = \begin{pmatrix} 1 & 1 \\ 0 & 1 \end{pmatrix} \quad \text{and} \quad T = \begin{pmatrix} 0 & -1 \\ 1 & 0 \end{pmatrix} .$$

Recall that the möbius action is *projective*

$$\begin{pmatrix} a\mu & b\mu \\ c\mu & d\mu \end{pmatrix} x = \frac{ax + b}{cx + d} .$$

Thus, one observes that the group $\text{PSL}(2, \mathbb{Z})$ (where we identify a matrix with its multiple by -1) is closely related to the theory of continued fractions. Recall that the larger group $\text{PSL}(2, \mathbb{R})$ acts on the upper half-plane (of \mathbb{C}), sending circles to circles and indeed as isometries with respect to the hyperbolic metric.

2. HECKE GROUPS AND ROSEN FRACTIONS

The Hecke (triangle Fuchsian) group, G_q , with $q \in \{3, 4, 5, \dots\}$ is the group generated by

$$S = \begin{pmatrix} 1 & \lambda \\ 0 & 1 \end{pmatrix} \quad \text{and} \quad T = \begin{pmatrix} 0 & -1 \\ 1 & 0 \end{pmatrix} ,$$

$$\lambda = \lambda_q = 2 \cos \pi/q .$$

When $q = 3$, we have $G_3 = \text{PSL}(2, \mathbb{Z})$. Now also let $U = ST$, so $U = \begin{pmatrix} \lambda & -1 \\ 1 & 0 \end{pmatrix}$ and one finds $U^q = \text{Id}$. Using this, one can show that G_q is the free product of finite cyclic groups: $G_q \cong \mathbb{Z}/2 \star \mathbb{Z}/q$.

Whereas any

$$\begin{pmatrix} a & b \\ c & d \end{pmatrix} , \quad ad - bc = 1$$

with integral entries gives an element of the modular group, when $q > 3$ one finds that G_q is of infinite index in $\text{PSL}(2, \mathbb{Z}[\lambda_q])$ and the *word problem* of determining whether a given matrix with elements in $\mathbb{Z}[\lambda_q]$ lies in G_q is no longer trivial.

2.1. Rosen Continued Fractions. In his 1952 Ph.D. dissertation published as [R], David Rosen proposed a new type of continued fraction to resolve this word problem. He decided to use the nearest integer multiple of λ_q as the a_i , and then with appropriate $\epsilon_i = \pm 1$ found expansions (of real numbers) of the form

$$\begin{aligned} \alpha &= a_0 \lambda + \frac{\epsilon_1}{a_1 \lambda + \frac{\epsilon_2}{a_2 \lambda + \frac{\epsilon_3}{\ddots}}} \\ &=: [a_0; \epsilon_1 : a_1 \lambda, \epsilon_2 : a_2 \lambda, \dots] . \end{aligned}$$

For each index q there is here also an underlying interval map, see Figure 1.

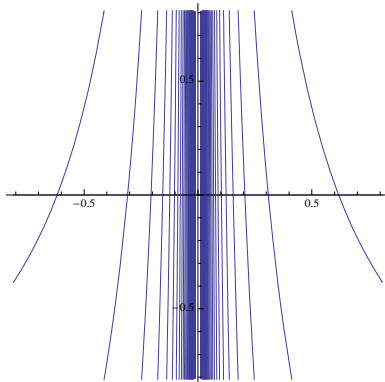

Figure 1: Approximate graph of interval map associated to Rosen fractions with $q = 5$. The branch at each extremity is not surjective.

2.1.1. *Rosen’s Cusp Challenge.* By continuity, we can extend the action of $\mathrm{PSL}(2, \mathbb{R})$ to include infinity: a matrix in our standard form sends infinity to $\frac{a}{c}$. By analogy with the classical case of $q = 3$, we call the G_q -orbit of ∞ the G_q -rationals. Rosen showed that for each q , set of real numbers of finite length Rosen continued fraction expansion is exactly the set of finite G_q -rationals. (The term *cusp* comes from the geometry of the quotient of the upper half-plane by the group.)

Rosen’s Cusp Challenge: Determine the orbit of infinity for each G_q .

When $q = 3$, one of course has that this orbit is exactly $\mathbb{Q} \cup \{\infty\}$; and for $q = 4, 6$ one easily determines the orbit, see [SS], [RT]. For $q = 5$ Rosen showed in 1963 that all of the units of $\mathbb{Z}[\lambda_5]$ are in the orbit of infinity. Leutbecher [Leu] completed this to show that $G_5 \cdot \infty = \mathbb{Q}(\lambda_5) \cup \{\infty\}$. In an impressive series of papers though 1985, Leutbecher, Borho, Rosenberger, Wolfart, Seibold showed that only for $q = 3$ or $q = 5$ is the cusp set exactly $\mathbb{Q}(\lambda_q) \cup \{\infty\}$. (Using techniques related to Veech groups, McMullen [Mc] determines the exact cusp set of hyperbolic triangle groups related to quadratic number fields, see also [C]. Compare these results with [Be].) Recently, Towse *et al.* [TetAl], extending techniques of this “German school”, show that both that (1) for any even q , there are infinitely many G_q orbits of elements of $\mathbb{Q}(\lambda)$, and (2) for odd q , the number of orbits of the field elements goes to infinity with q .

Although already in his thesis Rosen showed that $x = 1$ is periodic for all even q , in general the problem of characterizing those reals of periodic Rosen continued fraction expansion seems even harder than the cusp challenge.

2.2. **Further comments and references for the Rosen fractions.** As already hinted above, the parity of the index q of a Hecke group is significant. Many results must be phrased respecting this fact. (In a certain sense, the even index groups tend to be simpler.) For all $q > 3$, due to the end branches of the underlying not being surjective (in dynamical terms, the continued fraction map has non-full cylinders), there are restrictions on the possible consecutive sequences of (signed) partial quotients. Rosen determined these, they also depend strongly on the parity of the index. These restrictions can be viewed as coming from the orbits of the interval endpoints $\pm\lambda_q$; representations of “natural extensions,” such as given in the first two figures of [BKS], can help visualize these (non)-admissibility rules.

2.2.1. *Number theoretic aspects of the Hecke groups.* Each $\mathbb{Z}[\lambda_q]$ is the full ring of algebraic integers of the field $\mathbb{Q}(\lambda_q)$. Since λ_q is the sum of the root of unity $\zeta_{2q} := \exp 2\pi i/(2q)$ with its complex conjugate, $K = K_q := \mathbb{Q}(\lambda_q)$ is a number field of degree $n := \phi(2q)/2$ over the rationals, where ϕ denotes the Euler phi-function. See, say, [W] for these matters.

In fact, the field K_q is the maximal totally real subfield of the cyclotomic field $\mathbb{Q}(\zeta_{2q})$ — all field embeddings $\sigma_i : K_q \hookrightarrow \mathbb{C}$ into the complex numbers have real image. Using these embeddings, $\Gamma := \mathrm{PSL}(2, \mathbb{Z}[\lambda_q])$ acts on the n -fold product of the upper half-plane with itself; the action is sufficiently nice that the quotient under this action is an example of a Hilbert(-Blumenthal) modular variety. Each such Γ acts also on the K -projective line $\mathbb{P}(K) := K \cup \{\infty\}$, the orbits of

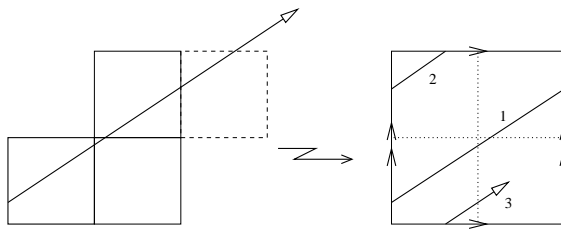

Figure 2: Unfolding; square table to torus surface.

this action are in 1–1 correspondence with the elements of the class group of \mathcal{O}_K (see say Exercise 1.7.3 of [B]). Since G_q is a subgroup of Γ , it is clear that the number of G_q -orbits of $\mathbb{P}(K_q)$ is at least this class number. Now, one can show that the class number of the K_q goes to infinity.

Even when we have an explicit G_q -rational, $x = a/c$, we must be careful — for $q > 3$ there are infinitely many units $\epsilon, \epsilon^{-1} \in \mathbb{Z}[\lambda_q]$. In a certain sense, the Rosen continued fraction gives a particular reduced representative of this element of the fraction field of $\mathbb{Z}[\lambda_q]$.

2.2.2. *Related continued fractions.* Rosen made an unfortunate choice in defining his fractions — they have a defect similar to the SCF in that not each step of the continued fraction map is given by an element of the group G_q . This can be fixed in various ways, Haas and others have used a continued fraction based upon taking the nearest greater integer multiple of λ_q . One can also take the sign differently while still using the nearest integer multiple. [DKS] begins a study of a continuum of continued fraction algorithms related to each G_q . (However, Smillie and Ulcigrai find that using continued fraction steps with negative determinant aids them in their coding of linear flow of the regular octagon[SU].)

2.2.3. *Other Aspects.* The article [SS] includes a brief review of much of the literature on the Hecke groups and Rosen continued fractions up to the early 1990s. Work mentioned there includes that by J. Lehner and of A. Haas and C. Series on diophantine approximation. Dynamical and metric aspects of the Rosen fractions has seen much interest, see especially the work of H. Nakada (*e.g.* [N]) and of C. Kraaikamp and various co-authors. Geodesic coding by way of SCF goes back to at least Artin [A], variants of the Rosen fractions have been used, [BS] is an instance in the physics literature. See also the recent [MS]. There continues to be much work on the (sub)group structure of the Hecke groups, see for example [LLT] and [IS]. Finally, B. Rittaud presented a fresh combinatorial perspective on continued fractions and these groups at the Numeration 2009 conference.

3. VEECH GROUPS — FLAT TORUS IS THE TOUCHSTONE

We turn to the geometric application; this section is directly influenced by the work of P. Arnoux and P. Hubert [AH]. See the very recent [SU] for related continued fractions. Forewarning: in this informal introduction, figures representing the geometry involved are quite helpful, however there is limited page space here. We strongly recommend that the interested reader turn to related surveys and introductions [HuS], [Z], [S], [Va], [G]. Particularly nice entry to the literature is given by [Vo] and [GJ]. Here, we can only attempt to hint at the interest of this subject.

The flat torus has optimal dynamics — when we follow a line, we either return to starting point or get arbitrarily close to every point. Say that a “flat” surface has *optimal dynamics* if the same dichotomy as for flat torus holds. To each such surface, one can associate a subgroup of $SL(2, \mathbb{R})$.

Theorem 1. (*Veech 1989*) *A “flat surface” has optimal dynamics if its associated group is appropriately large in $SL(2, \mathbb{R})$.*

W. Veech [V] gave examples with this group being isomorphic to (an index 2 subgroup of) the Hecke group, G_q . The straight line flow on a flat surface is of interest for several reasons; one of these is that given any billiard table in the form of a Euclidean polygon with vertices that are rational multiples of π , the possible paths of the billiard correspond to geodesics on a flat surface made by gluing together an appropriate collection of copies of the polygon; See Figures 2 and 3.

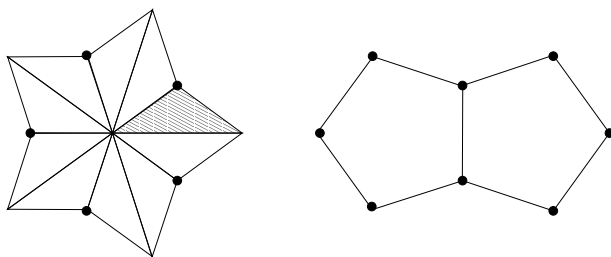

Figure 3: Triangle with angles $(\pi/5, \pi/5, 3\pi/5)$ yields a genus two surface: flat except for one point of angle 6π ; same translation surface. Parallel sides are identified by translation.

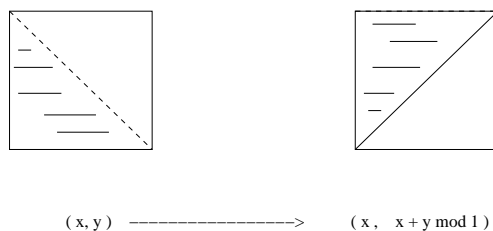

Figure 4: The classic affine Dehn twist — vertical circles are sent to circles. Left and right ends are fixed, thus a (locally affine) self-map of the flat square torus results.

Much progress has been made in the study of the dynamics of these polygonal tables by using this construction, see say [KMS] for a landmark paper.

When X is (an appropriately defined) “flat” surface, an *affine diffeomorphism* is some $f : X \rightarrow X$ whose *derivative* (off of singularities) is constant $A \in \mathrm{SL}(2, \mathbb{R})$. The group of all these derivatives is the Veech group: $\mathrm{SL}(X, \omega)$. (The notation (X, ω) comes from thinking of the surface X with a flat structure ω — this ω can be seen as a holomorphic differential on X with a complex structure.) Besides rotations, such as that of order 5 on the surface of Figure 3, the easiest elements to envision come from (nice) decompositions of X into cylinders. Indeed, a cylinder is given by identifying opposite edges of a rectangle, and viewing this as a fibering of an interval by circles, we can map each circle to itself by twisting by an amount linearly increasing from zero twisting to a full rotation. Figure 4 gives a representation of this so-called *Dehn twist* when the rectangle is the standard square; its derivative is $A = \begin{pmatrix} 1 & 0 \\ 1 & 1 \end{pmatrix}$. Thus, whenever X is the union of cylinders in some direction, there is a diffeomorphism defined piecewise by the Dehn twists in each cylinder. Rarely, the cylinders match so well that appropriately composing powers of the Dehn twist in each cylinder with itself results in a diffeomorphism whose derivative is given by a common matrix. An example of this is hinted at in Figure 5; there the corresponding element of $\mathrm{SL}(X, \omega)$ is $\begin{pmatrix} 1 & 0 \\ \mu & 1 \end{pmatrix}$, $\mu = 2(1 + \sqrt{2})$. This and the obvious rotation generate all of $\mathrm{SL}(X, \omega)$, a group isomorphic to an index 2 subgroup of G_8 .

Given a chosen set of generators of an appropriate type of matrix group, we can often create some analog of continued fractions, see [BSe]. When the group is $\mathrm{SL}(X, \omega)$, (under certain hypotheses) finite length expansions correspond to period directions on X . Combining the work of [AH] with results of Leutbecher, one can show that the set of periodic directions on octagon is given by slopes in $\mathbb{Q}(\sqrt{2})$. Similarly, for the 12-gon, find $\mathbb{Q}(\sqrt{3})$. But for the decagon, one finds a proper subfield of $\mathbb{Q}(\mu_{10}) := \mathbb{Q}(2 \cot \pi/10) = \mathbb{Q}(\sqrt{5 + \sqrt{5}})$.

Related to this, Rosen’s result that 1 has periodic expansion for even q gives $(1 + \cos \pi/q) / \sin \pi/q$ is a non-periodic direction on the $2q$ -gon. In fact, there is a corresponding pseudo-Anosov diffeomorphism — pseudo-Anosov diffeomorphisms are in a certain the main interest in the geometric side of this material, as emphasized by W. Thurston, see say [T].

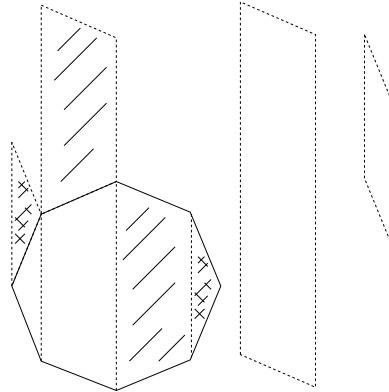

Figure 5: The octagon surface decomposes into two vertical cylinders, the Dehn twists in these exactly match.

REFERENCES

- [AH] P. Arnoux, P. Hubert, *Fractions continues sur les surfaces de Veech*, J. Anal. Math. 81 (2000), 35–64.
- [A] E. Artin, *Ein mechanisches System mit quasi-ergodischen Bahnen*, Abh. Math. Sem. Hamburg 3 (1924) 170-175 (and *Collected Papers*, Springer-Verlag, New York, 1982, 499-505).
- [Be] F. Berg, *Dreiecksgruppen mit Spitzen in quadratischen Zahlkörpern*, Abh. Math. Sem. Univ. Hamburg 55 (1985), 191–200.
- [BS] E. Bogomolny and C. Schmit, *Multiplicities of periodic orbit lengths for non-arithmetic models*, J. Phys. A: Math. Gen. 37, (2004) 4501-4526.
- [BSe] R. Bowen, C. Series, *Markov maps associated with Fuchsian groups*, Inst. Hautes Études Sci. Publ. Math. No. 50 (1979), 153–170.
- [B] D. Bump, *Automorphic forms and representations*, Cambridge Studies in Advanced Mathematics, 55. Cambridge University Press, Cambridge, 1997.
- [BKS] R. Burton, C. Kraaikamp, and T.A. Schmidt, *Natural extensions for the Rosen fractions*, TAMS 352 (1999), 1277–1298.
- [C] K. Calta, *Veech surfaces and complete periodicity in genus two*, J. Amer. Math. Soc. 17 (2004), no. 4, 871–908
- [DKS] K. Dajani, C. Kraaikamp, W. Steiner, *Metrical theory for α -Rosen fractions*, preprint. ArXiv : 0702516.
- [G] E. Gutkin, *Billiards in polygons: Survey of recent results*, J. Stat. Phys. 83 (1996), 7 – 26.
- [GJ] E. Gutkin and C. Judge, *Affine mappings of translation surfaces: Geometry and arithmetic*, Duke Math. J. 103 (2000), 191 – 213.
- [TetAl] E. Hanson, A. Merberg, C. Towse, and E. Yudovina, *Generalized continued fractions and orbits under the action of Hecke triangle groups* Acta Arith. 134 (2008), no. 4, 337–348.
- [HuS] P. Hubert, T. A. Schmidt, *An introduction to Veech surfaces*; in: Handbook of dynamical systems. Vol. 1B, 501–526, Elsevier B. V., Amsterdam, 2006.
- [IS] I. Ivriissintzis, D. Singerman, *Regular maps and principal congruence subgroups of Hecke groups*, European J. Combin. 26 (2005), no. 3-4, 437–456.
- [KMS] S. Kerckhoff, H. Masur, and J. Smillie, *Ergodicity of billiard flows and quadratic differentials*, Ann. Math. 124 (1986), 293 – 311.
- [LLT] M.-L. Lang, C.-H. Lim, S.-P. Tan, *Principal congruence subgroups of the Hecke groups*, J. Number Theory 85 (2) (2000) 220–230.
- [Leu] A. Leutbecher *Über die Heckeschen Gruppen $G(\lambda)$* , Abh. Math. Sem. Hamb. 31 (1967), 199-205.
- [MT] H. Masur and S. Tabachnikov, *Rational billiards and flat structures*, in Handbook on Dynamical Systems, Elsevier 2001, in press.
- [MS] D. Mayer and F. Strömberg, *Symbolic dynamics for the geodesic flow on Hecke surfaces*, J. Mod. Dyn. 2 (2008), no. 4, 581–627.
- [Mc] C. McMullen, *Teichmüller geodesics of infinite complexity*, Acta Math. 191 (2003), no. 2, 191–223
- [N] H. Nakada, *Continued fractions, geodesic flows and Ford circles*, in Algorithms, Fractals and Dynamics edited by Y. Takahashi, 179–191, Plenum, 1995.
- [R] D. Rosen, *A Class of Continued Fractions Associated with Certain Properly Discontinuous Groups*, Duke Math. J. 21 (1954), 549-563.
- [SS] T. A. Schmidt, M. Sheingorn, *Length spectra of the Hecke triangle groups*, Math. Z. 220 (1995), no. 3, 369–397
- [S] J. Smillie, *Dynamics of billiard flow in rational polygons*; In: Ya. G. Sinai (ed) Dynamical Systems. Encycl. Math. Sci. Vol. 100. Math. Physics 1. Springer Verlag, 360 – 382 (2000)
- [SU] J. Smillie and C. Ulcigrai *Symbolic coding for linear trajectories in the regular octagon*, preprint arXiv:0905.0871.

- [T] W. Thurston, *On the geometry and dynamics of diffeomorphisms of surfaces*, Bull. A.M.S. 19 (1988), 417 – 431.
- [RT] D. Rosen, C. Towse, *Continued fraction representations of units associated with certain Hecke groups*, Arch. Math. (Basel) 77 (2001), no. 4, 294–302.
- [Va] M. Viana, *Ergodic theory of interval exchange maps* Rev. Mat. Complut. 19 (2006), no. 1, 7–100.
- [V] W.A. Veech, *Teichmüller curves in modular space, Eisenstein series, and an application to triangular billiards*, Inv. Math. 97 (1989), 553 – 583.
- [Vo] Ya. B. Vorobets , *Plane structures and billiards in rational polyhedra: the Veech alternative (Russian)*, Uspekhi Mat. Nauk 51, 3–42, (1996); translation in Russian Math. Surveys 51:5 (1996), 779–817
- [W] L. Washington, *Introduction to cyclotomic fields*, GTM 83. Springer-Verlag, New York, 1997.
- [Z] A. Zorich, *Flat surfaces*; in: Frontiers in number theory, physics, and geometry. I, 437–583, Springer, Berlin, 2006.

Oregon State University, Corvallis, OR 97331 • toms@math.orst.edu